

Gąsienice gumowe

Do maszyn:

- Airmann
- Atlas
- Bobcat
- Case
- Caterpillar
- Chikusui
- Daewoo
- Eurocat
- Euromach
- Eurotom
- Eurotrac
- Gehl
- Hanix
- Hinowa
- Hitachi
- IHI
- JCB
- Kobelco
- Komatsu
- Kubota
- Messeri
- Neuson
- Peljob
- Sunward
- Takeuchi
- Terex-Schaeff
- Yanmar
- ...



TOTALSOURCE®
 Parts and Accessories



Gąsienice TotalSource®
 Bardziej wytrzymałe dzięki taśmom
 wzmacniającym bez łączenia
 (walcowane z jednego kawałka stali)

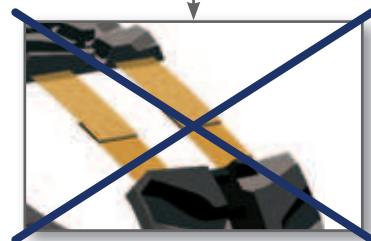

Tradycyjne gąsienice
 Słabsze ze względu na łączoną
 taśmę wzmacniającą.

Na życzenie!

Dostępne również gąsienice niebrudzące
 (ograniczona oferta)



Gąsienice gumowe

Identyfikacja rozmiaru



Marka maszyny:

Typ maszyny:

Szerokość gąsienicy (w mm):

Odstęp (w mm):

Ilość ogniw:



Szerokość (w mm)

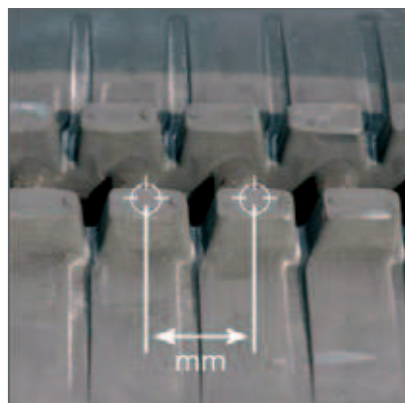

Odstęp (w mm)



Ilość ogniw

Gąsienice gumowe

Specyfikacja gąsienic gumowych



Szer. x Odstęp	Ogniwa	A	B	C	D	E (sworzeń stal.)	Prowadzenie
150x72	29 ↔ 40	21	64	23	24	25	A2
180x60	30 ↔ 40	23	60	28	26,5	26	A1
180x72	28 ↔ 58	23	68	28	27	26	A2
180x72k	30 ↔ 37	20	61	22	19,5	-	B2
200x72	34 ↔ 47	27	80	28	31	32	A2
200x72k	37 ↔ 47	24	68	30	30	34	A2
230x48	60 ↔ 84	23	74	25	25	24	B1
230x72	42 ↔ 56	23	76	30	26	40	A2
230x96	30 ↔ 48	24	74	22	24	26	B1
230x101	30 ↔ 36	24	75	23	29	22	B1
250x47	84	25	66	23	20	21	B2
250x48,5 (offset)	84	24	66	21	20	-	B2
250x52,5	72 ↔ 78	30	80	22	21	24	B2
250x72	47 ↔ 57	23	76	30	26	40	A2
260x96	35 ↔ 38	24	76	24	20	21	B2
260x107		30	84	24	26	24	-
260x109	35 ↔ 39	29	86	26	29	31	B1
280x72	45 ↔ 64	25	78	30	24	31	A2
280x106	35 ↔ 42	30	80	28	28	30	B2
300x52,5n	72 ↔ 98	30	78	22	18	25	B1
300x52,5w	72 ↔ 92	40	92	24	21	28	B1
300x52,5k	70 ↔ 84	29	86	28	31	24	B2
300x53	80 ↔ 84	31	88	25	19,5	-	B2
300x55	70 ↔ 86	30	82	26	26	25	B1
300x55,5 (offset)	76 ↔ 82	30	82	23	27	27	B2
300x109N	35 ↔ 42	30	78	27	28	22	B1
300x109W	35 ↔ 44	40	90	27,5	29	30	B2
300x109K	37 ↔ 41	28	86	24	28	30	B1
320x54	70 ↔ 84	30	82	22	17	25	B1
320x84 (SSL)	50 ↔ 53	45	104	45	34	38	C2
320x86 (SSL)	48 ↔ 52	36	84	48	29,5	39	C2
320x90	52 ↔ 56	32	85	48	35	40	C2
320x100	38 ↔ 54	28	82	32	25	42	A2
320x106	39 ↔ 43	32	82	27	26	32	B2
350x52,5	70 ↔ 92	40	90	24	23	28	B1
350x54,5	80 ↔ 86	40	92	23,5	22,5	-	B2
350x56	84	39	90	26	18	28	B1
350x56R	84	39	90	26	18	28	B2
350x75,5	74	40	102	23	25	33	C2
350x109	41 ↔ 44	39	96	22	29	34	B1
370x107	39 ↔ 41	38	92	26	26	32	B2
400x72,5N	70 ↔ 80	39	96	27	26	32	B1
400x72,5W	68 ↔ 92	50	105	28	25	35	B1
400x72,5K	68 ↔ 76	38	96	30	27	32	B2
400x72,5R	74	50	100	29	24	35	B2
400x72,5Y	72 ↔ 74	28	86	30	24,5	-	C2
400x75,5	74	40	102	23	23	33	C2
400x107	46	38	92	29	28	33	C2
400x142K	36 ↔ 37	30	90	32	28	44	C2
400x144	36 ↔ 41	42	100	27	20	36	B1
420x100	50 ↔ 58	50	98	51	36	44	A2
450x71	76 ↔ 88	43	118	25	20	40	B1
450x73,5	76 ↔ 84	42	120	30	32	-	B1
450x76	80 ↔ 84	48	118	30	30	38	B1
450x81N	72 ↔ 80	40	116	26	23	40	B1
450x81W	72 ↔ 78	58	142	30	30	42	B1
450x83,5K	72 ↔ 74	40	116	26	28	40	B1
450x83,5Y (Offset)	74	42	112	23	27	-	B2
450x84 (SSL)	53 ↔ 56	45	100	47	33	40	C2
450x90	58 ↔ 76	40	90	39	33	36	A2
450x100 (SSL)	48 ↔ 65	50	104	47	44	45	C2
450x163	38	39	120	29	30	44	B2
500x90	76 ↔ 82	46	100	52	35	43	A2
500x92	72 ↔ 84	48	130	28	28	43	B1
600x100	76 ↔ 80	48	113	60	49	-	A2
700x100	80 ↔ 98	48	125	75	58	-	A2
750x150	66	62	176	94	68	-	A2

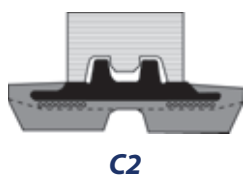
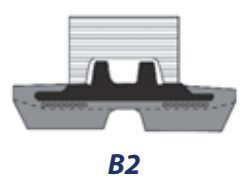
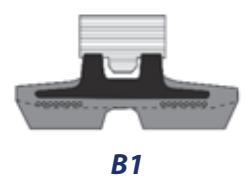
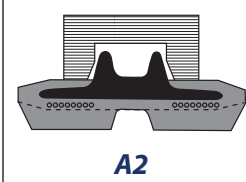
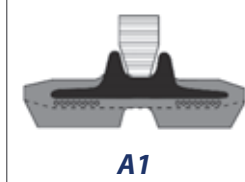
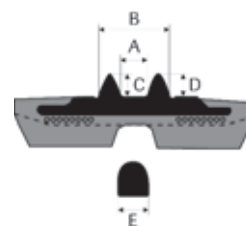
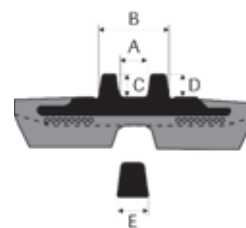

Nakładki gumowe na metalowe gaśienice

Identyfikacja rozmiaru nakładki



Z jednym wypustem*

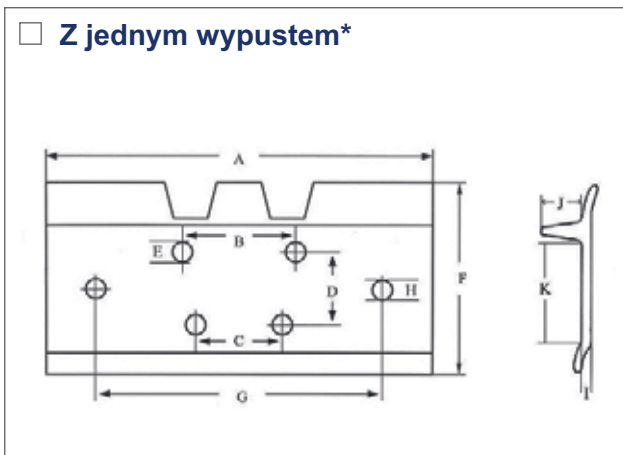

Z dwoma wypustami*

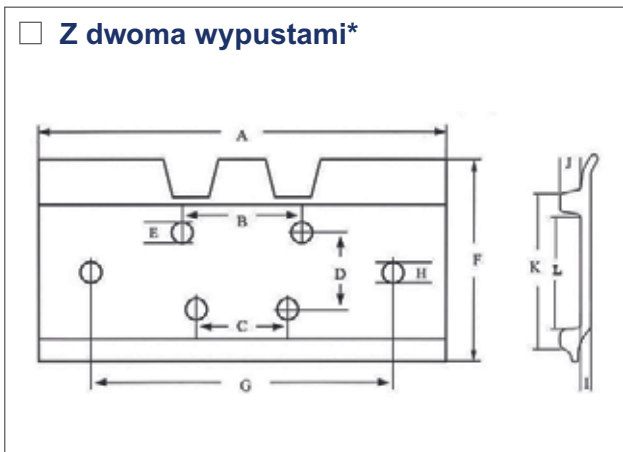

Z trzema wypustami*

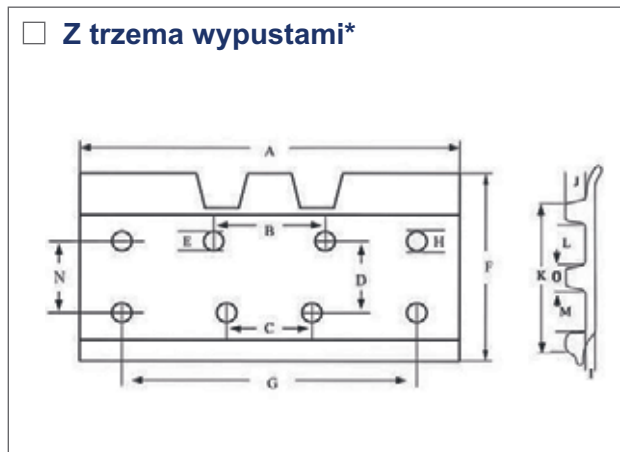

Typ maszyny:

Model:

Ilość ogniw:

A: F: K:

B: G: L:

C: H: M:

D: I: N:

E: J: O:

* Wybierz odpowiednią wersję zaznaczając krzyżykiem.

Kontakt

Wózki Widłowe ARTECH

ul. Firmowa 12, 34-321 Łękawica
Tel./Fax 33 862-26-06 / 33 862-25-72
www.artech-wozki.pl

Rafał Hubczak

e-mail: r.hubczak@widlak.net
Tel. 33 862-32-32
Tel. kom. 606-999-757

Marek Broda

e-mail: m.broda@widlak.net
Tel. 33 862-32-12
Tel. kom. 600-798-660